

## VALVE BLOCK REMOVAL INSTRUCTIONS

These instructions are for the 28 machine only. You will need to replace a brass fitting, add a lock-washer, and remove the valve block.

Tools Required: 5/16" wrench or socket, 10" adjustable wrench.

1. Read all instructions completely before beginning.
2. Unplug the quick-disconnect from the air system and reduce the resistance to zero.
3. Remove both hoses from the tank, and remove the tank by loosening the hex jam nut. Unscrew the single-barbed fitting from the tank bushing, and place the internal tooth lock-washer over the tank bushing, re-install the hex jam nut. Now place a few drops of "Loctite 242" on the threads of the new double-barbed fitting provided, and install it into the top of the tank bushing. Re-install the tank with the lock-washer under the tank bracket. Tighten the hex jam nut, and re-connect both hoses to the tank.
4. Pull hoses "A", "B", and "C" from the valve block, and slide the flow restrictor over hose "A". Connect all three hoses together using the plastic "Y" connector provided (SEE ILLUSTRATION). Remove hose "D" from the valve block. Carefully insert your finger into the access hole at the base of the seat (SEE ILLUSTRATION) and locate hose "D". Pull hose "D" out of the base and plug it onto the remaining barb on the tank. Stuff any excess hose back into the frame.
5. Remove the valve block using a 5/16" wrench or socket.
6. Plug the quick-disconnect back into the air system, and check for air leaks.
7. The gage needle should take approximately 6 seconds to travel from the 9 o'clock position to the 12 o'clock position. Make adjustments to the flow restrictor using an allen wrench to achieve the proper fill rate. Use Loctite on the set screw when done.

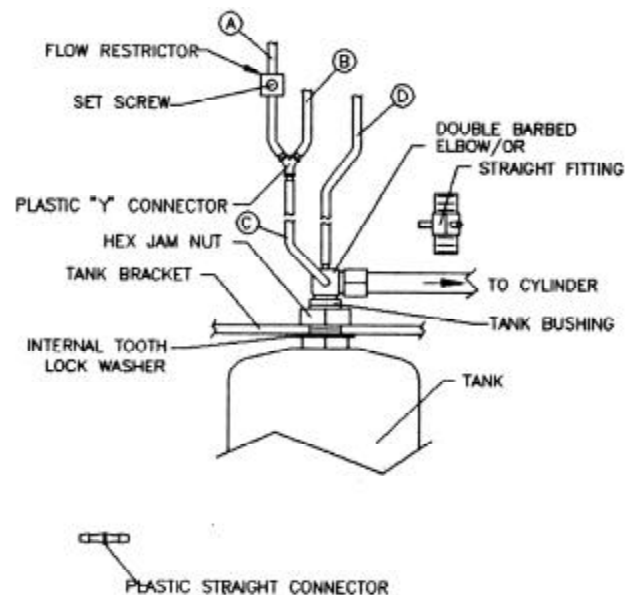
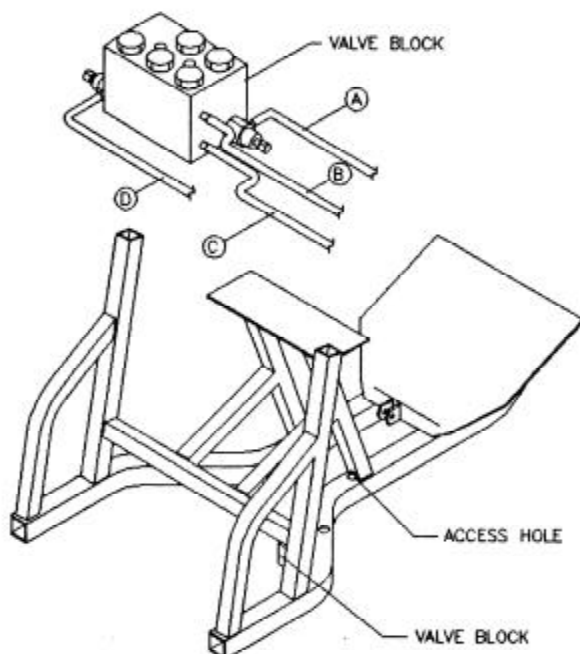

REV. A  
4/16/93  
28-5401