

Compressor Models 1021 & 1022

Maintenance Manual

Fourth Edition



KEISER

COMPRESSOR MODEL 1021 / 1022

Features:

Model 1021:

- 115 VAC at 60 Hz, 1/2 hp, 500 watts, 5 amps
- Rated flow is 1.5 CFM at 100 psig

Model 1022:

- 230 VAC at 50 Hz, 1/3 hp, 375 watts, 2.5 amps
- Rated flow of 1.2 CFM at 100 psig

The following features are included with both models.

- Quiet operation, noise level of approximately 47 db at 3 feet.
- Delivery of clean, dry, and oil-free air at room temperature.
- Unit dimensions of 26"x15"x14"
- 2.5 gallons of air storage tanks
- Delivery of pressurized air between 100 psig and 125 psig
- Computer controlled

Description of Compressor

The compressor is divided into four major components. The compressor motor, the air drying system, the storage tanks, and the computer control system.

- *The air drying system.*
The system consists of a dryer module and purge tank.
- *The storage tanks.*
The tanks hold the pressurized air produced by the compressor.
- *The computer control system.*
The computer control system controls and regulates the pressure that is delivered by the compressor.
- *The compressor motor.*
The compressor motor is located within a sound insulated chamber inside the housing assembly. This is where the air is compressed and where most of the noise is generated.

Servicing

Caution: Prior to performing any type of service to this unit, perform the following steps. Failure to follow these procedures may result in serious physical harm to you and/or damage to the unit.

Safety procedures:

1. Prior to servicing the compressor, unplug unit from electrical supply.
2. Slowly bleed all pressure stored in the compressor using the drain valve located on one side of the compressor next to the Quick Disconnects (figure 1).

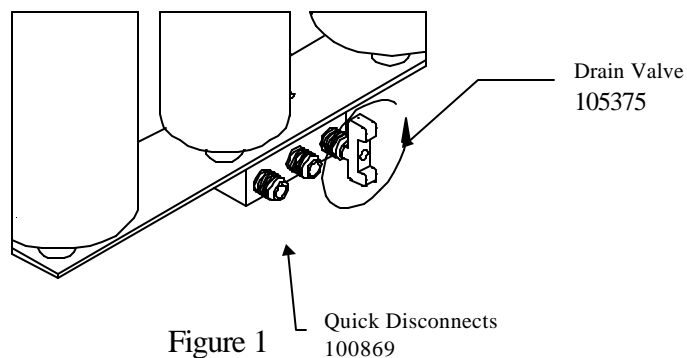

3. After bleeding all of the pressure out of the compressor, close the drain valve.

The Air Drying System

- The air drying system consists of a dryer module and a purge tank. The dryer module is the small center tank that has a black air line attached to the top. The drying module's main purpose is to extract any moisture that may exist within the system and deliver dry pressurized air to the main air line. The purge tank is the center tank located on the opposite side of the dryer module. The purge tank's purpose is to dry the crystals in the dryer module canister (figure 2).
- Servicing of the dryer module is recommend when the drying module becomes so saturated with moisture that it allows moisture to pass through it and into the main air pressure line. Moisture will be visible in the exercise machine's filter element (refer to machines maintenance manual).
-

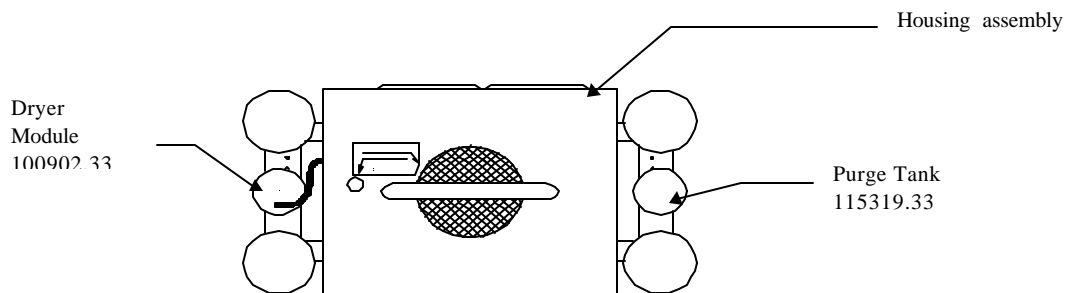

Figure 2

- The air dryer module was designed to be replaced without having to disassemble any of the major components. Using a standard screwdriver, unscrew the small screw that attaches the hose on to the top of the canister (figure 3).

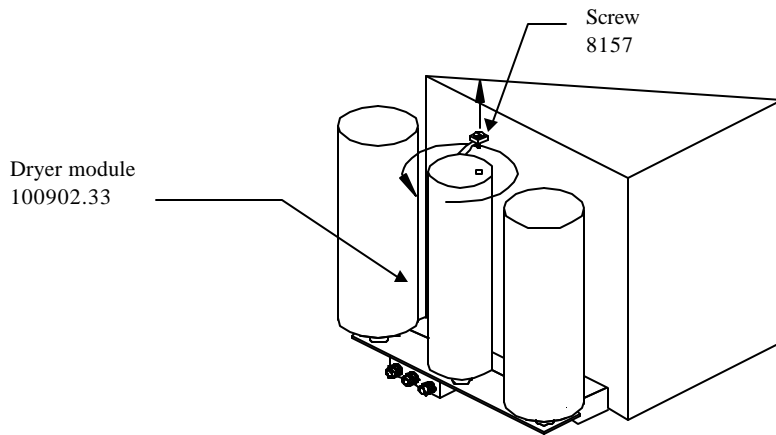

Figure 3

- Twist the air dryer canister counter clockwise until it is completely loose. Pull the canister straight up. Be careful not to damage the copper tube that travels up inside the canister (figure 4).

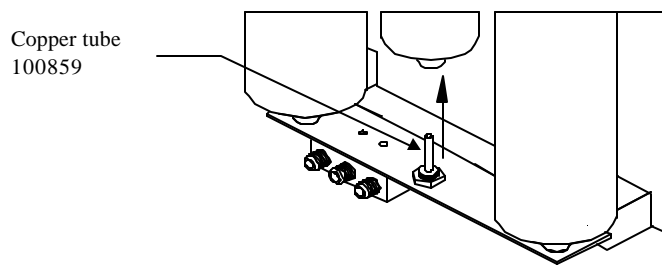

Figure 4

- Replace with a new canister, carefully sliding the copper tube up inside bottom opening of canister. Twist canister clockwise hand tight and attach screw with hose back to the top of the new canister.

Air Intake Filter

- The air intake filter is located within the housing assembly and filters all air entering the system. The Keiser compressor unit was designed to operate in an environmentally controlled room. The servicing of this filter is dependent upon the location of the compressor. If the compressor is located in a dirty or harsh environment, the filter must be checked or serviced

every 6 months. When the compressor unit is located in a clean environment the frequency of servicing may be extended to approximately 2 years.

- A quick test can be performed to see the condition of the filter assembly. Disconnect all air lines going out of the compressor leading to the exercise machines. Allow the compressor
- to run and shut off at full pressure. Using the drain valve, slowly bleed air out of the compressor. When the compressor starts, close the valve and time how long the compressor runs. The compressor should run less than 60 seconds before all the storage tanks are pressurized and the motor shuts off. If the motor runs longer, the air intake filter may need servicing.

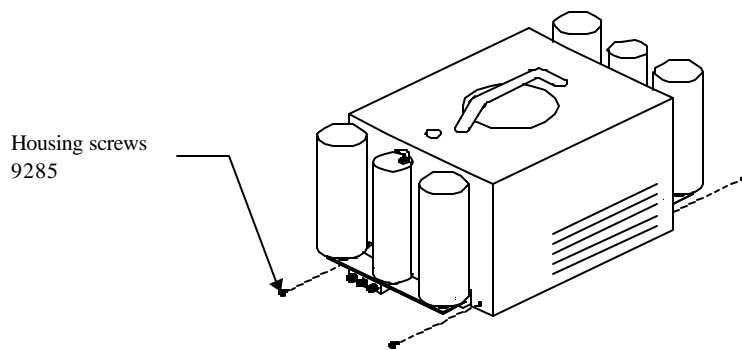

Figure 5

- Servicing of the air intake filter requires the removal of the housing assembly. The housing assembly can be removed by unscrewing the four (4) screws that attach the housing to the frame. Two screws are located on each side of the compressor behind the storage tanks (figure 5). After removing screws, pull housing assembly straight up being careful not to damage the foam on the inside.
- Twist the entire filter housing off and remove it from the unit (figure 6).
- Replace filter housing with a new one and reinstall Housing assembly onto the frame.

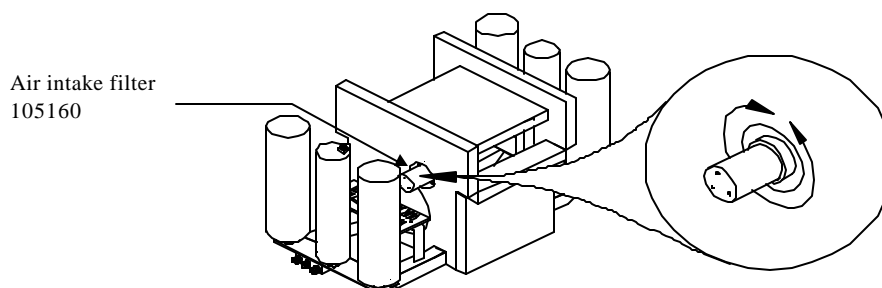

Figure 6

Troubleshooting

Keiser Corporation has always taken pride in designing and engineering the highest quality equipment on the market. Only the highest quality products have the *Keiser* name on, and this compressor is no exception. In the unlikely event that any malfunctions may occur, the following section will facilitate troubleshooting and replacing any part(s) that may fail.

LED

- The compressor has an LED that displays the pressure and also any errors it might encounter while it is running. If you suspect a problem, look at the display to see if an error code is displayed. Normally the display will be reading pressure which is done by sequentially displaying the pressure as one number after another. If there is an error the display will read “E r” and then a number and keep repeating this until the error corrects itself or the unit is unplugged and plugged back in to attempt to fix the error. The following is a list of error codes and their meaning:

E r 1 - The check valve is leaking. Once the compressor builds up pressure and shuts off, the pressure is bleeding down rapidly to a low pressure of approximately 10 psi. Replace check valve.

E r 2, E r 8 - The unit is running for an extend period of time before shutting down. This error is given when the unit runs for over an hour and pressure is not reaching the shut off setting (approximately 120 psi). The unit will still shut off every 5 minutes to allow itself to purge the dryer assembly, even if it does not reach the shut off setting, displaying **E r 8**. If, after 20 cycles, the unit fails to reach the shut off pressure, the compressor will shut down and not restart, displaying **E r 2**. This condition means there must be a leak within the system. Disconnect all exercise machines from the compressor, reset the compressor by disconnecting and reconnecting it from its electrical supply. Run the compressor and note if the compressor builds up pressure and shuts off. A view hole on the housing assembly will allow you to see at what pressure the compressor shuts off. If the compressor does build up pressure and shuts down, the leak is in one of the exercise machines or any air supply lines leading to them. The machines should be plugged in one at a time to see which one has the leak. If the compressor fails to shut down while the machines are unplugged, then the leak is in the compressor. Inspect the compressor closely for leaking hoses or fittings.

E r 3, E r 4, E r 5 - Purge tank pressure did not drop fast enough. The purge tank must bleed air through the dryer to regenerate it. This must happen before the compressor can restart. If this takes too long, then this error will be displayed. Probable cause is the solenoid valve or dryer module is plugged.

E r 6 - Computer thinks the motor did not start. The motor was given a signal to start but no pressure increase on the purge tank was detected. Motor or start circuit could be faulty. Listen when the compressor starts and see if the motor starts or the solenoid valve closes. If the motor does not start and the solenoid valve clicks, then the motor is faulty and must be replaced. If the solenoid valve does not click and the motor does not start, then the computer board must be replaced. If the motor runs then check plumbing to insure that all hoses are connected.

E r 7 - Compressor stopped because pressure did not rise in storage tanks. A large leak exists in one of the exercise machines or in the compressor plumbing.

E r 9 – Pressure is building too slowly. The intake muffler may be plugged.

DIP SWITCHES – On all Rev H and earlier boards

The functions of the dip switches are:

SW1 places the unit in a mode that causes it to display the pressure on PS1 (tank pressure). If this switch is on when the power is first turned on, the compressor will never start. The normal position for this switch is OPEN or OFF.

SW2 places the unit in a mode that causes it to display the pressure on PS2 (dryer pressure). If this switch is on when the power is first turned on, the compressor will never start. The normal position for this switch is OPEN or OFF.

SW3 is not functional on the current design. Always leave this switch in the OPEN or OFF position.

SW4 When closed, will cause the LED display to read the number of hours the motor has run.

SW5 When closed, will cause the LED display to read the number of times the motor has started.

SW6 Is used to calibrate span at the factory. Always leave this switch in the OPEN or OFF position.

SW7 is used to calibrate zero at the factory. Always leave this switch in the OPEN or OFF position.

Note: *Push button switches (Rev I and later) replaced dip switch. Pushing the button marked “starts” will display the number of starts of the compressor. Pressing “hours” will display the total hours the motor has run. Pressing both buttons will give the pressure in the purge tank.*

Caution: *Follow all safety procedures prescribed earlier.*

Check Valve

- A check valve is installed between the purge tank and the main air pressure in the storage tanks. This check valve allows the purging of the drying module and the purge tanks while maintaining system pressure to the main air pressure lines.
- If the pressure in the storage tanks bleeds down at the same rate as the pressure in the purge tank, the most likely problem is the check valve. This will be confirmed by an error code on the Computer control system (CCS) circuit board (Refer to the CCS section on page 10).
- The housing assembly must be removed (Refer to the Air intake filter section on page 3).

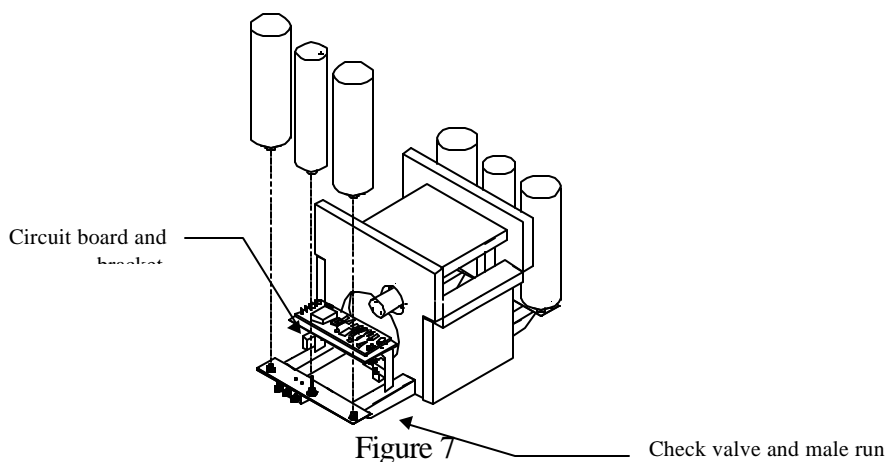

- The check valve is mounted on the under side of the mounting bracket that holds the circuit board and bracket (figure 7).
- Remove the dryer module (reference The Air Drying System). Remove the two adjacent storage tanks using the same method used on the dryer module.
- Label “Top hose” and “Bottom Hose” and remove the air hoses that are connected to the end cap. Follow the procedures for removing hoses in the Solenoid Valve section following this section.

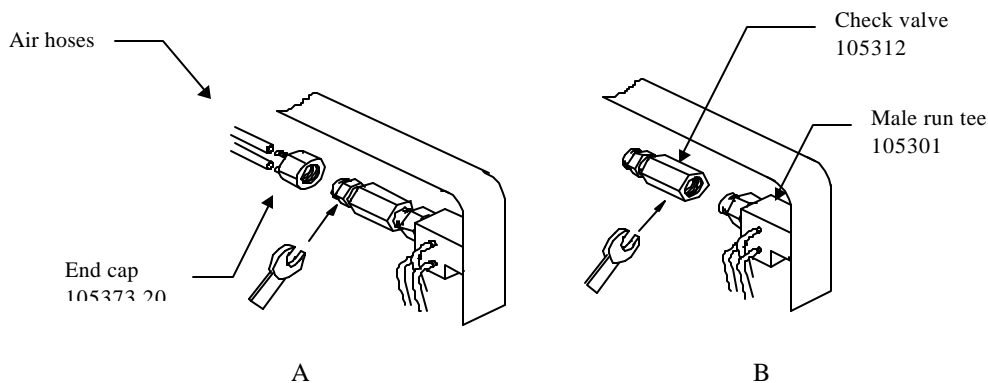

Figure 8

When unscrewing the end cap, a wrench must be placed on the outer portion of the check valve to keep it from rotating (figure 8, view A).

- To unscrew the check valve, place a wrench on the inner portion of the valve and rotate it (figure 8, view B).
- To install the new check valve, clean threads on the male run tee. Apply a small amount of “Loctite ®” on the thread. Install the check valve, place the wrench on the inner portion of the valve and rotate (figure 8, view B).
- Apply a small amount of “Loctite ®” to the threads on the check valve. Place a wrench on the outer portion of the valve, hold the valve and screw on the end cap (figure 8, view A).

Note: The end cap has two barbs that are attached to it. One of the barbs has a smaller orifice than the other. Make sure the barb with the small orifice ends up on top while the other barb is directly underneath it.

- Reinstall the air hoses to the end cap using the labels to attach the hoses to their corresponding locations.

Solenoid Valve

- The solenoid valve is located within the housing assembly. The valve aids in purging air through the air dryer canister. This valve is mounted to the side of the bracket that supports the computer control circuit board (figure 9).

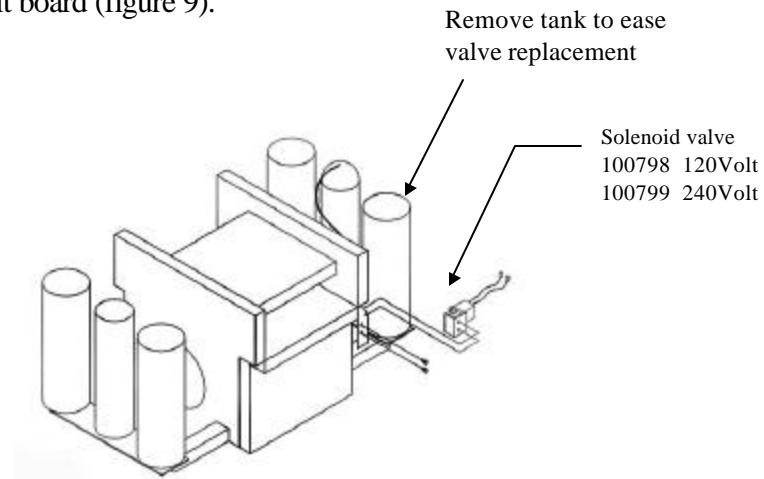

Figure 9

- Two wires from the solenoid valve are connected to the circuit board. Remove wires from circuit board by holding electrical terminals and pulling straight up.

In April 2001, the blue Mac valve (105300) was replaced by a red Allen Air (100798,9); this valve has proven to be more reliable.

- To remove hoses from the blue Mac valve, use a pair of needle nose pliers, place the jaws on either side of the air hose, and *gently* pry the hose off the barb that is mounted to the valve. Take care not to damage the barbs (figure10).

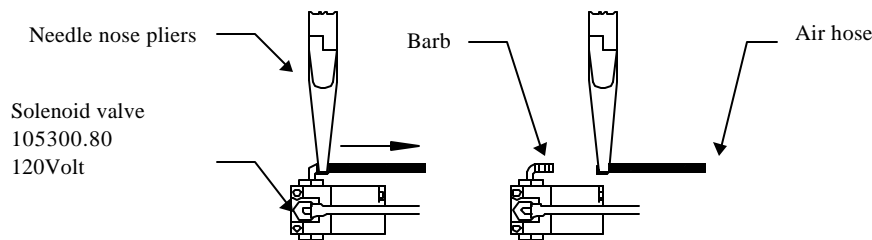

Figure 10

- To remove the hoses from a red Allen Air valve (100798,9), use a ½ open end wrench, and unscrew the compression nut attached to each hose.
- If the hose was previously installed over a bar, trim 3/8” off the hose.
- Install the new valve and tighten the mounting screws.
- Press the insert into the end of each hose. Push the end of the hose into the compress align nut, until it bottoms out. Tighten the nut one turn past hand tight if this is the first time this hose has been crimped. If you previously removed the compress align nut and it is already crimped to the hose, then tighten by hand and use a wrench just to snug the compress align nut.
- Reconnect the wire terminals of the red Allen Air valve to terminals marked V1 and V3 on the circuit board with revision L.

Note: On circuit boards with revision I and earlier, connect solenoid wires to terminals V1 and L1.

Compressor Motor

- The *Keiser* compressor motor is a highly durable motor that should last years without experiencing malfunctions. If the motor fails to perform and, after talking to our service department, it is determined that a new motor is needed, we recommend shipping the entire unit to Keiser Corporation for a replacement unit.
- If you need to replace the motor yourself, the following procedures will assist you.

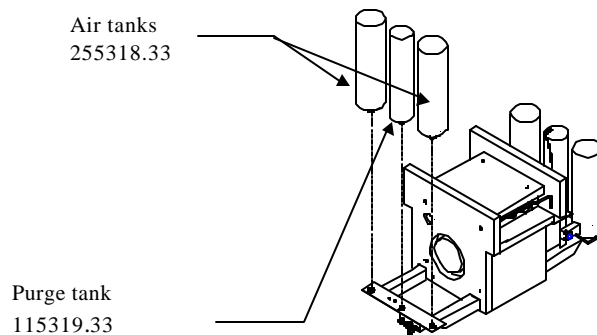

Figure 11

- Remove the housing assembly and remove both air tanks and the purge tank by unscrewing each tank counter clockwise and pulling them straight up (figure 11)

- Remove top and side foam pieces. Each piece of foam has four (4) screws that secure them into place (figure 12).

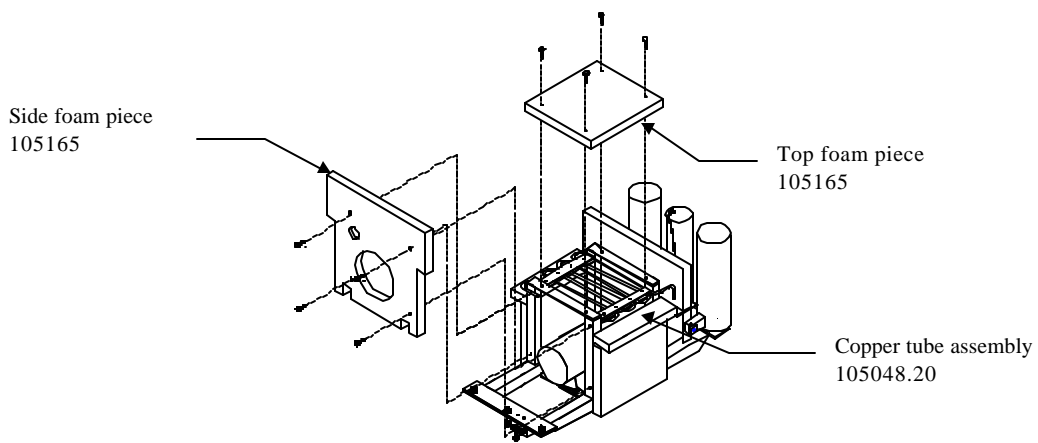

Figure 12

- Unhook air lines that lead to both ends of the copper tube assembly.

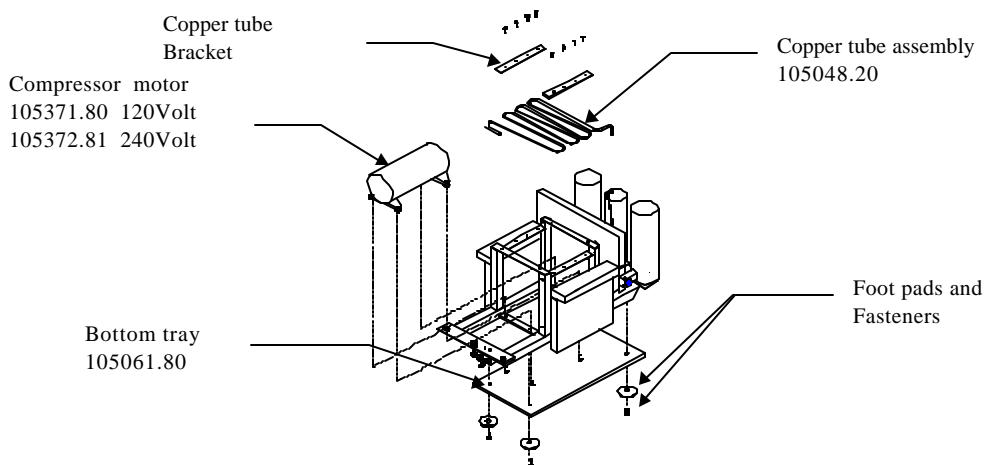

Figure 13

- Remove top brackets that secure the copper tube assembly on to the frame. These brackets are secured in place by four (4) screws each. Remove copper tube assembly.

- Disconnect the electrical wires from the motor that lead to the computer control circuit board.
- To be able to access the compressor's motor bolts and hardware, the compressor's bottom tray must be removed. The tray is held in place by the four bolts that mount the compressor's footpads (figure 13).
- Remove the fasteners that mount the motor onto the frame assembly and pull the motor out. The motor must be rotated slightly to fit through the frame assembly.
- Replacement of new motor is done in reverse order of disassembly.

Computer Control Circuit Board (CCS)

- The computer control system (CCS) controls and regulates the compressor's motor. It monitors the pressure system and aids in troubleshooting when it senses a problem. If the CCS senses any irregular conditions, it will display a system error code on the LED, located on the circuit board. If the CCS senses a serious condition, the CCS will shut the entire system down and flash an error code on the LED (figure 14). All codes are explained in the troubleshooting section of this manual.

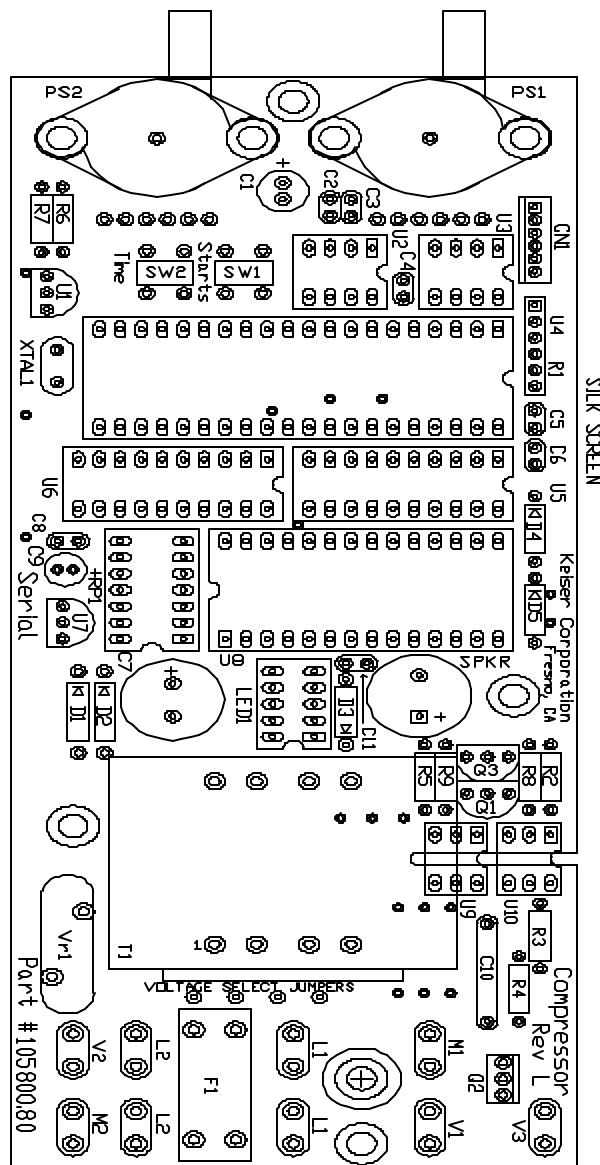

- The CCS also has the capability of sensing the presence of multiple compressors on the same main air pressure line. Under these conditions the CCS will change the start and stop pressures to that individual compressor so that each compressor runs at a maximum efficiency rate, giving each compressor equal run time.
- Servicing of the CCS circuit board will become necessary in the unlikely event the board fails to operate within the specifications set by the Keiser Corporation. The CCS circuit board is located within the housing assembly. Replacing the CCS circuit board is the only servicing that may be done. When servicing the circuit board, the circuit board and bracket will be removed as one unit.
- All terminal connections are clearly marked on the circuit board. We recommend that you label each wire using a pen and masking tape, as you remove them. This will help you when the time comes to reinstall all wiring. In the event that the labeling comes off or is not available, follow the circuit board diagram (Table 1).
- Once all wire connections have been removed, remove the air hoses using the same procedure described earlier. We also recommend you label the air hoses.

Circuit Board Terminals	Wire Source	Wire Color
M1 LED	Motor	Black
V1	*See Note	Black
L1	Power	Black
L2	Power	White
V2	*See Note	Black
M2 Circuit Board Fuse	Motor	White
V3	*See Note	Black

Table 1

- Remove the hardware that mounts the circuit board and bracket to the mount bracket (Figure 15).

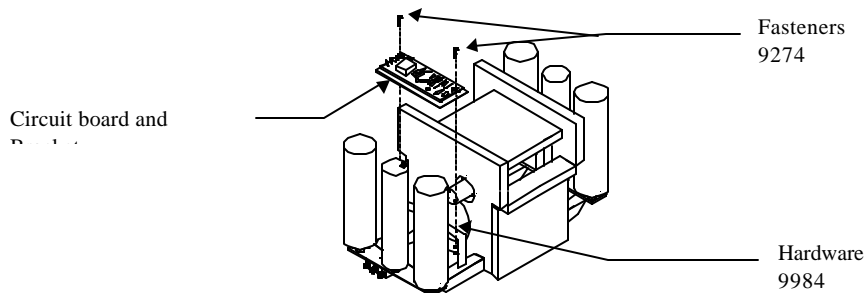

Figure 15

- Replace with new circuit board and bracket. Reinstall all fasteners.
- Trim ends of air lines, reinstall.

- Reinstall all wire connections using either Table 1 or the labels that were placed on each wire connection.

Note: Blue Mac Valve connects across V1 and V2.

Red Allen Air valve connects across V1 and V3 on boards with revision K and higher, and on V1 and L1 on boards with Revision J and earlier.

For any service problems or questions call 1-(800)-888-7009

10-5470-Rev E