

Table of Contents

Assembly Instructions	1
Assembly Figure	4
Maintenance Instructions	5
Daily	5
Weekly	5
Lubricating the Chain	5
Check Friction Belt	6
Clean Bike	6
Monthly	6
Chain Guard Check	6
Wax the Bike	6
Clean the Chain	6
Check Chain Tension	7
Check Bottom Bracket & Crank Arms	7
Check Shifter Cable Assembly	8
Check Flywheel Adjustment	8
Clean and Lubricate Flywheel Groove	9
Lubricate Shift Lever	10
Lubricate Handle Bar Clamp Handle Threads	10
Adjustments	11
User Adjustments	11
Maintenance Adjustments	14
Removal of Chain Cover	14
Chain Tension & Flywheel Adjustment	15
Friction Belt Adjustment	17
Shift Lever Tension	19
Seat (Non-adjustable)	19
Replacement of Friction Belt.....	19
Bottom Bracket Installation	21
Torque Specifications	22
Tools	22
Trouble Shooting	23
Parts List	24
Exploded Detail Diagram	25

INTRODUCTION

KEISER CORPORATION has always taken pride in designing and engineering the highest quality equipment on the market. This means that you will receive years of low maintenance and minimal repairs from every one of our machines. Only the highest quality products have the KEISER name on them.

This manual was written with the customer in mind. It will assist you in the unlikely event that our KEISER Power Pacer or Free Wheel develops any type of problems. This manual covers everything from daily maintenance to replacements of any worn parts. In essence, any problems that may develop are addressed in this manual.

This manual provides a detail breakdown of all of the KEISER Power Pacer/ Free Wheel, with a full list of part numbers at time of publication. Since we always find ways to improve our products, parts and machine designs are subject to change without notice. If you have any question, please call our service department at **(800) 888-7009**.

WORD DEFINITIONS

SAFETY CAUTIONS and WARNINGS:

We've put a number of safety cautions in this book. We use the word ***Caution!*** to tell you about things that could cause bodily injury to persons on or around the equipment if you were to ignore the following instructions and the word ***Warning!*** to ensure the proper installation of components and that the instructions are followed for the safety of the users and for maximum machine life or the warranty is void.

HINTS:

We use the word ***Note!*** in this book to tell you about things that we recommend you doing or things to be aware of before performing the instructions. These notes were placed in the manual to aid you during a certain procedure.

Warning!

Failure to follow the assembly or operation instructions as provided by this manual or any other instructions pertaining to the assembly and/or operation of KEISER equipment will result in voiding the warranty and could lead to serious injury.

ASSEMBLY INSTRUCTIONS

<i>Tools Required:</i>	<i>1/2 inch socket</i>	<i>Paste Wax (not included)</i>
	<i>1/2 inch wrench</i>	<i>Ex. Turtle Wax (Paste type)</i>
	<i>9/16 inch wrench</i>	<i>Crescent wrench</i>
	<i>15mm socket</i>	<i>Torque wrench</i>
	<i>Small #1 Phillips screw driver</i>	<i>15mm Crows Foot</i>

Caution!

The unit should only be operated with the chain cover guard fitted correctly, as supplied. Children in the area and users are vulnerable to injuries to fingers if the unit is used without the chain cover guard. Refer to Monthly Maintenance section A. on chain lubrication and cover checking.

A. Unpack

Tools Required: 1/2 inch socket or wrench

1. Remove the bike and the following loose parts from the packing box :
 - a) Handlebar Assembly
 - b) Front and Rear Foot
 - c) Pedals
 - d) Set of 4 Bolts, Nuts and Washers for Feet
 - e) Seat (Adjustable Seat Post option only)
 - f) Handle Bar Slug
 - g) Loctite 242 (supplied)

B. Waxing

Tools Required: Paste wax and a Clean cloth

1. Prior to assembling the frame and feet assembly, a coat of paste wax **must** be applied. This will help protect the powder coat paint on the frame and feet.
2. Apply the wax in accordance to the wax manufacture's procedures.

Warning!

Failure to apply wax as instructed will decrease paint and frame life due to sweat and the warranty will be void.

C. Feet (see Figure 2)

Tools Required: 1/2 inch wrench, 1/2 inch deep well socket and torque wrench

1. Remove the round black plugs from the access holes near the center of the feet and set them aside.
2. Attach the front (with casters) and rear feet to the frame using the 5/16" x 3/4" long bolts, flat washers (under the head of the bolt) and lock nuts. The bolts should be torqued to 15 ft-lb.
3. Reinsert the black plugs

D. Pedals (see Figure 2)

Tools required: 15 mm wrench (narrow) or pedal spanner, Loctite 242 (supplied), 15mm crows foot, torque wrench

1. The right side pedal (side with chain) has right hand threads (clockwise rotation) and the left side pedal has left hand threads (counterclockwise rotation). Most pedals are marked indicating which pedal is for the left side (marked with an “L”) and right side (marked with an “R”). Apply a small amount of Loctite 242 to the threads of both pedals and attach the pedals to the crank arms being careful not to cross the threads. Pedals should be tightened to approximately 35 ft-lb. ***Failing to install the crank arms with Loctite 242 or crossing the threads will ruin the crank arms and void the warranty. In no case should the pedals be left loose on the crank arms as the pedals may pull out of the crank arms damaging them and causing serious injury.***

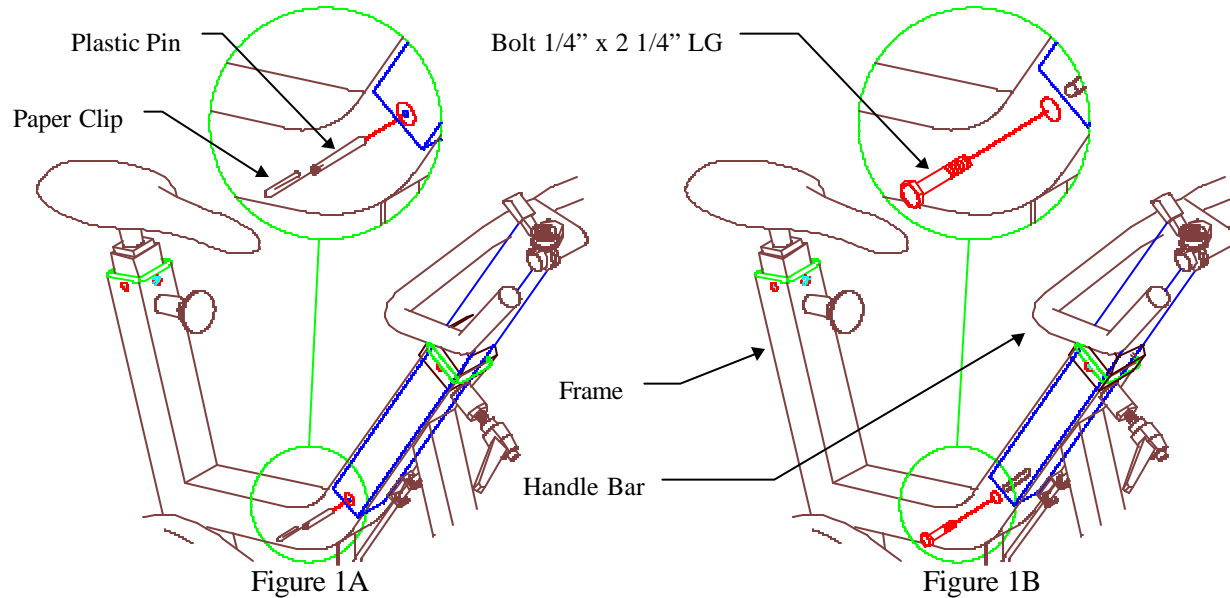

E. Handle Bar (see Figure 1A-B & 2)

Tools Required: Small Phillips screwdrivers

1. Loosen the handle bar clamp several turns.
2. Insert the handle bar into the frame as shown in Figure 1A.

Caution!

The following steps must be performed to keep the handle bar from accidentally coming out and causing serious injury to the rider

3. While looking through the holes on the side of the handle bar frame tube, slide the handle down into the frame tube until the ¼ inch holes in the handle bar line up with the holes in the frame tube (Figure 1A).

4. Unbend one leg of the large paper clip (supplied) and slide the ¼ inch plastic dowel over this end as illustrated in Figure 1A. This paper clip will be used to support the dowel as you insert the dowel through the holes in the handle bar. Be careful to insure that the dowel has passed through both holes of the handle bar tube. The dowel will remain in this tube and slide up and down with the handle bar inside the main frame tube. Once the dowel is inserted into the handle bar, move the handle bar up slightly so that you can gently pull the paper clip out without the dowel coming out.

Warning!

Failure to install the plastic dowel into the handle bars will void the warranty and could cause serious injury resulting from the handle bars coming out of the frame.

5. Attach the shifter to the handle bar. The shifter is held in place by a clamp and is positioned so that the lever rotates parallel to the handle bar and the cable runs down the front side of the handle bar.

Assembly Figure

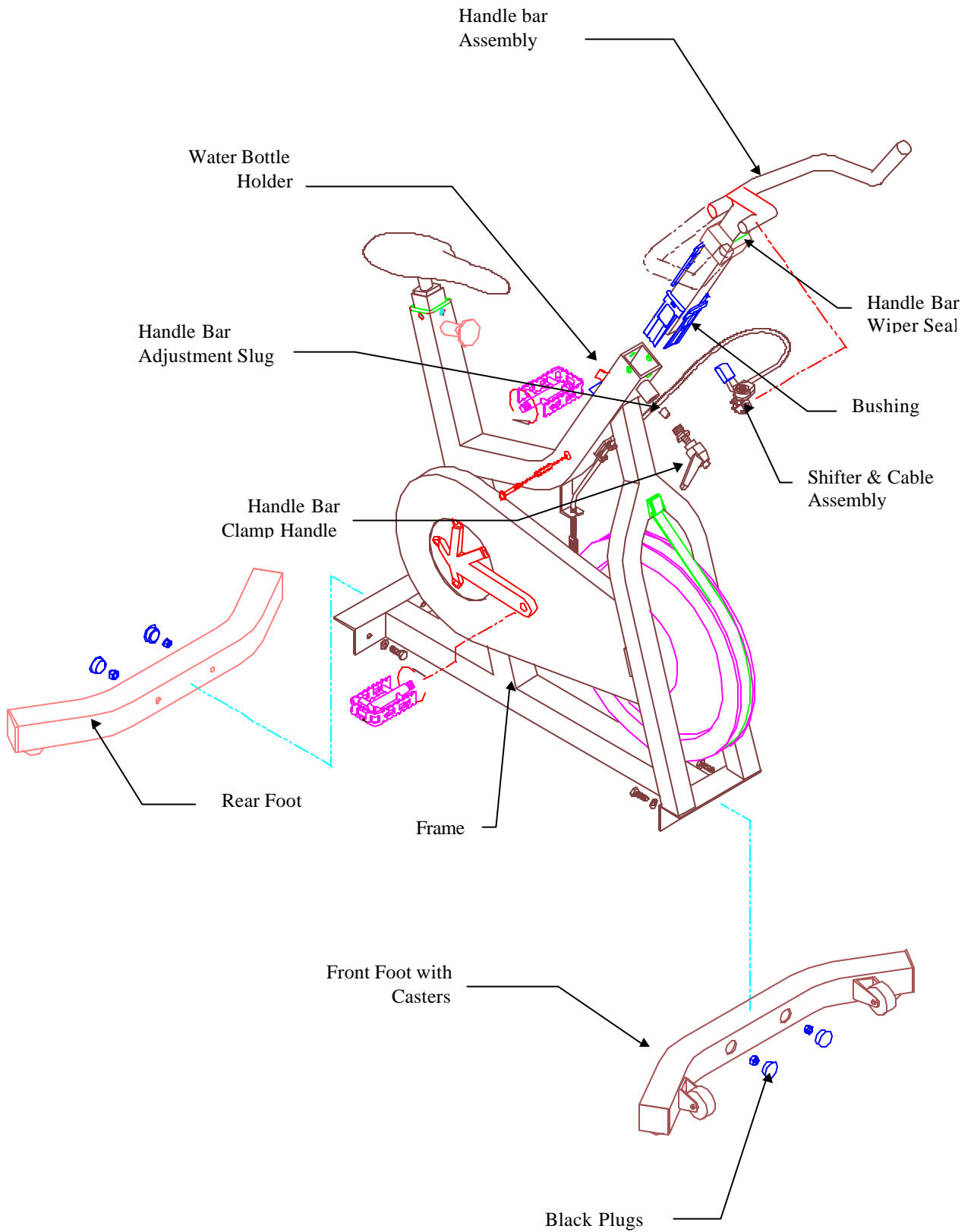

Figure 2

MAINTENANCE

<i>Tools Required:</i>	<i>“BEL RAY” Chain Lube with Molyphos Additive</i>	
	<i>Tape Measure</i>	<i>9/16 wrench</i>
	<i>Clean Cloth</i>	<i>9/16 socket</i>
	<i>Mild Soap</i>	<i>Chrome Polish</i>
	<i>Small #1 Phillips screw driver</i>	<i>Paste Wax (not included)</i>
	<i>Standard #2 Screw Driver</i>	<i>Ex. Turtle Wax (Paste type)</i>
	<i>Bottom Bracket socket</i>	

DAILY

- Wipe down the entire bike after every workout with a clean dry cloth.

Caution!

The unit should only be operated with the chain cover guard fitted correctly, as supplied. Children in the area and users are vulnerable to injuries to fingers if the unit is used without the chain cover guard. Refer to Monthly Maintenance section A. on chain guard cover checking.

WEEKLY

A. Lubricating the Chain

Tools Required: - *“Bel Ray chain lube with Molyphos Additive” is recommended*

This lubricant is initially foam that quickly begins to become a fluid, which drips off the chain.

- a) Remove the chain cover guard using a flat head screwdriver to pop out the four plastic rivets on the cover.
- b) After removing the chain guard, place it under the chain to catch any excess lubrication.
- c) Slowly rotate the flywheel by turning the pedal with one hand, while spraying the lubricant on the inside of the chain, into the gaps of the chain. Rotate the flywheel until the entire chain has been lubricated.
- d) Take a cloth and wipe out the excess lubricant from inside the chain case. Wipe out the inside of the chain guard, which was used to catch excess lubricant.
- e) Replace chain cover guard and pop in the plastic rivets.

B. Check Friction Belt

Tools Required: None

1. To loosen belt completely, remove all tension on the belt by placing the shift lever on the handle bars to the lowest setting (full clockwise rotation).
2. Inspect both sides of the Friction Belt for excessive wear. If the belt has been worn through, the belt needs to be replaced. See instructions under *“Replacement of Friction Belt.”*

C. Clean Bike

Tools Required: Clean Cloth, Spray on Wax/Cleaner-“*Turtle Wax, Wax/Cleaner*” is Recommended.

1. Spray the bike with a spray on wax/cleaner and wipe down the seat, handle bars, chain cover and bike frame.
2. ***Thoroughly*** wipe down the frame with a clean cloth.

MONTHLY

A. Chain Guard check

Tools Required: None

1. Visually check the chain guard for any breaks or cracks.
2. Make sure chain guard is securely fastened to the unit.

B. Wax the Bike (*The purpose of applying wax regularly is to prevent rust caused by sweat.*)

Tools required: Clean Cloth, Warm Mild Soap & Water, Paste Wax & Chrome Polish

Warning!

Failure to apply a coat of paste wax at least once a month as instructed below will decrease paint and frame life due to sweat and the warranty will be void.

1. Wipe down the seat, handle bars and chain cover with a mild soap and water solution.
2. ***Thoroughly*** dry the frame with a clean cloth.
3. Apply wax to the seat (this will help seal the surface) and bike frame in accordance to wax manufacture’s procedures.
4. Apply the chrome polish to the seat post tube and handle bar tube.

C. Clean the Chain

Tools Required: Screw Driver, Clean Cloth

Caution!

Extreme care must be taken not to allow your fingers, clothes, hair, etc. to be drawn into the chain and sprockets. This will cause severe injury.

1. Keeping the chain clean will help to extend the life of the chain and drive components.
2. Remove the chain cover following the direction under “*Removal of Chain Cover*”.
3. While rotating the chain *very slowly* hold the clean cloth over the chain removing any loose dirt or foreign material from the chain.
4. Once the chain is clean, lubricate the chain as instructed under “*Lubrication of Chain*”.
5. Replace the chain cover.

C. Check Chain Tension

Tools Required: Tape measure

Caution!

Extreme care must be taken not to allow your fingers to be drawn into the chain and sprockets. This will cause severe injury.

1. Maintaining proper chain tension will help to extend the life of the chain and drive components. We recommend that the chain be checked at the same time it is cleaned. Removing the chain cover is necessary to check and clean the chain, follow the instructions under “*Removal of Chain Cover*”.
2. Set the shift lever at the full load position (counter clockwise, Figure 10). Gently move the crank arm back and forth being careful not to rotate the flywheel. The movement of the end of the crank arm (at the pedal) should not be more than 1/8 of an inch. If the movement of the arm is greater than 1/8 of an inch the chain may be out of adjustment.
3. If the chain is out of adjustment, adjust the chain using the instructions under the section “*Chain Tension & Flywheel*” adjustment.
4. If the chain is properly adjusted and still makes noise the chain may be worn or one of the chain sprockets may be worn and in need of replacement.

D. Check Bottom Bracket & Crank Arms

Tools Required: Torque wrench and Bottom Bracket socket

1. Monthly re-torque the crank arm bolts to 35 ft-lbs..
2. Check to see if the bottom bracket is loose by wiggling crank arms back and forth.
3. If the bottom bracket is loose in the frame re-torque to 57 ft-lbs.
4. If the bottom bracket spindle appears to move within the bottom bracket bearing, then the bottom bracket may be worn out and needs replacement. To replace bottom bracket see page 24 and follow instructions.

E. Check Shifter Cable Assembly

Tools Required: None

1. Inspect the shifter cable assembly for damage or excessive stretch or slipping of the cable.
2. The cable assembly is preset at the factory for proper adjustment. A small amount of cable slack can be taken out by adjusting the cable housing at the adjustable ferrule (Figure 3).
3. If the cable is severely damaged, it may be replaced using a standard 1.2mm stainless steel shifter cable available at any bicycle shop or it may be ordered from Keiser.
4. If the entire assembly is damaged it may be replaced with one ordered from Keiser.

Ferrule Adjustment

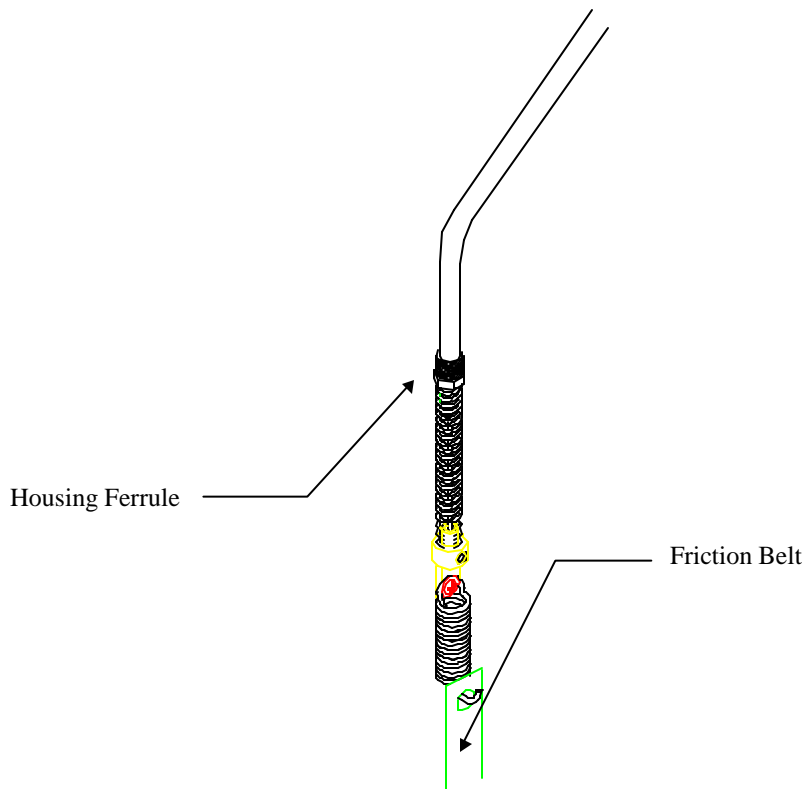

Figure 3

F. Check Flywheel Adjustment

Tools Required: Tape Measure

1. Stand a few feet away facing the front of the Keiser bike. Look at the alignment of the flywheel with respect to the seat tube and fork tubes. If the Flywheel does not appear to be parallel to these tubes, it probably is out of alignment and needs adjustment. A more precise method of checking the alignment requires measuring the distance from one side of the flywheel, at the top edge, to the inside edge of the fork tube (Figure 4). From the same side of the flywheel, but at the bottom edge, measure the distance to the inside of the same fork tube. These distances should be about the same (within about 1/8").

2. If the flywheel is out of adjustment, you need to align the flywheel following the instructions given in the “Chain Tension & Flywheel” adjustment section.

Front View

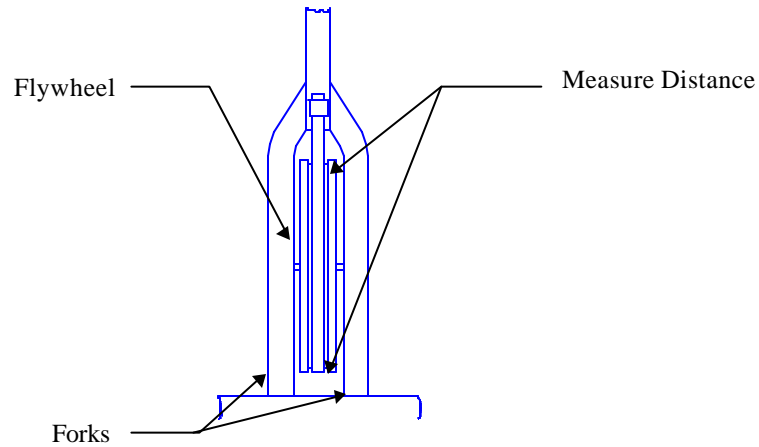

Figure 4

G. Clean and Lubricate Flywheel Groove

Tools Required: Sanding sponge, Clean cloth and Oil

1. Remove the friction belt from the flywheel (Figure 5).
2. Apply a generous amount of TFL 50 wet lube to the groove to break up any corrosion on the flywheel. Wipe off all corrosion and debris with clean cloth.

Caution!

Use extreme caution when sanding flywheel. When sanding flywheel position sanding sponge on the flywheel as shown in Figure 5, keeping hands, fingers, clothes, etc. away from bike frame to avoid them from getting snagged or pinched. Failure to follow instructions could result in serious injury.

3. While rotating the flywheel (possibly by having someone *slowly* pedal the bike) hold the sanding sponge in the groove of the flywheel (as shown in Figure 5). Clean the groove with a dry cloth removing all debris created from sanding sponge. Replace friction belt.

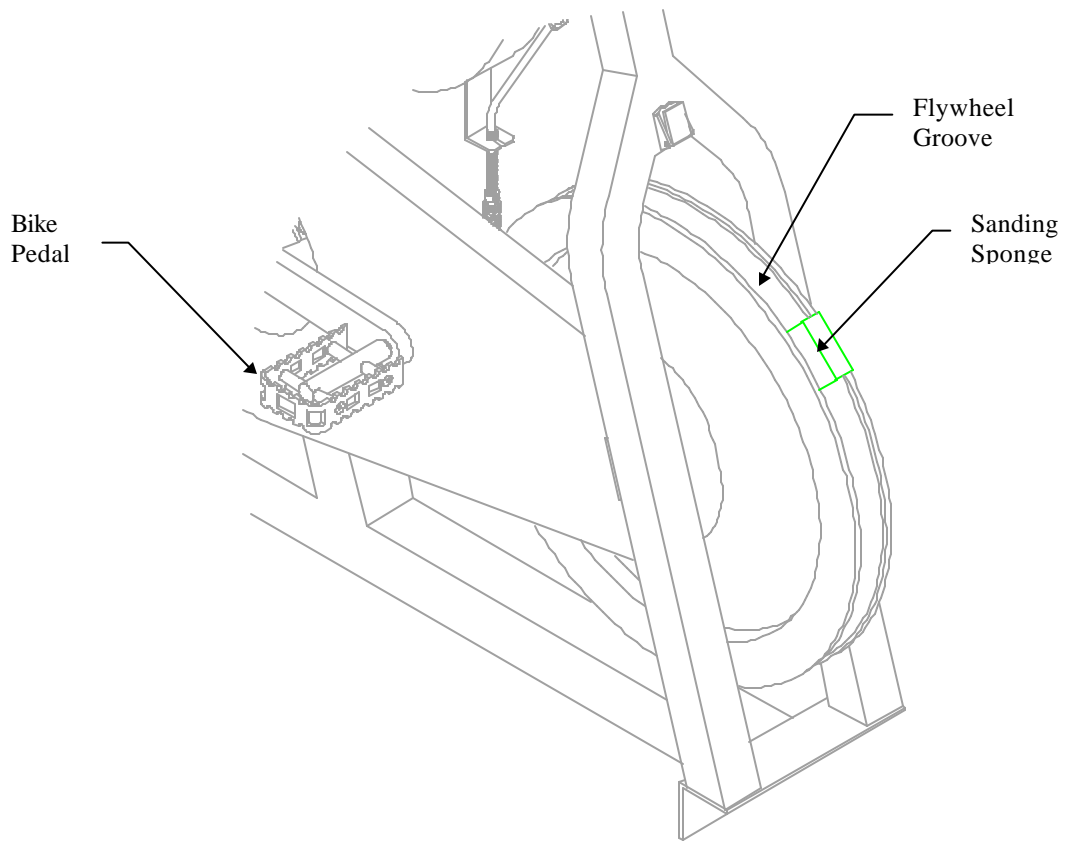

Figure 5

H. Lubricate Shift Lever

Tools Required: Lubricate oil

1. Using one hand, clamp two fingers on top and a thumb on the bottom of the shifter assembly unit. Loosen the shift lever tension bolt about $\frac{1}{8}$ of an inch (Being careful not to allow the small plastic shifting spring inside the Shifting assembly unit to fall out). Lift the shift lever tension bolt, the thread should be visible (Figure 10).
2. Apply lubricate oil to the thread of the shift lever tension bolt and top and bottom of the shifter lever where it is bolted. Re-tighten shift lever tension bolt.

I. Lubricate Handle Bar Clamp Handle Threads

Tools Required: Lubricate oil

1. Grabbing hold of the handle bars, turn lever counter clockwise to completely loosen the handle bars (Figure 9).
2. Apply lubricate oil to the thread of the handle bar.
3. Wipe-off any excess oil and reinstall the handle.

ADJUSTMENTS

The following section of this manual will consist of two sections. The first section will include all adjustments that can be done by the club member (user). The second section will include all maintenance adjustments that should be done by a qualified club maintenance person.

Drive Train Figure

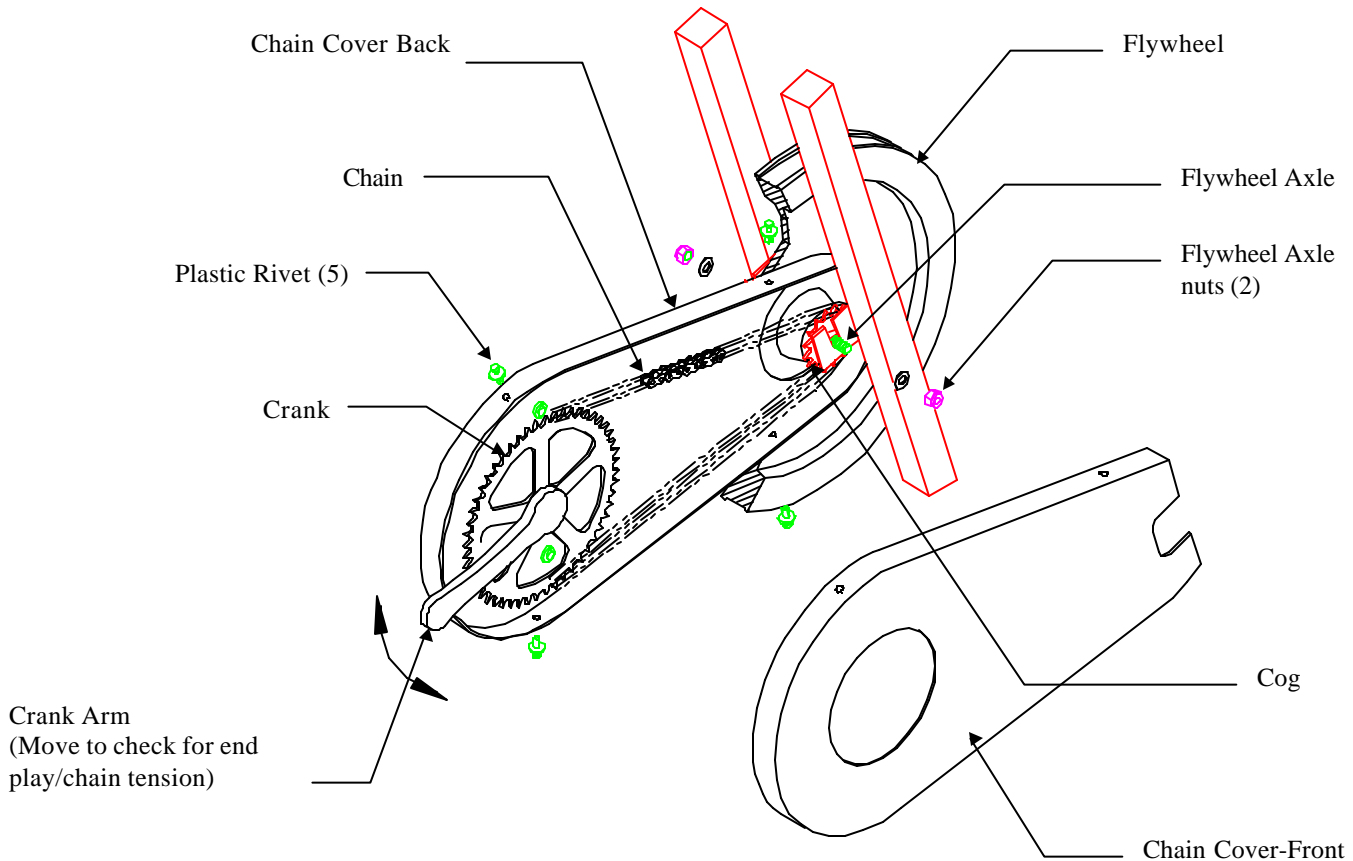

Figure 6

User Adjustments

A. Seat Height adjustment

1. The seat height adjustment may be done in increments of 1".
2. Grab hold of seat (Figure 7).
3. Pull seat adjustment pin out.
4. Adjust seat to preferred height.
5. Release pin and move seat up or down until pin locks.

Seat Height Adjustment

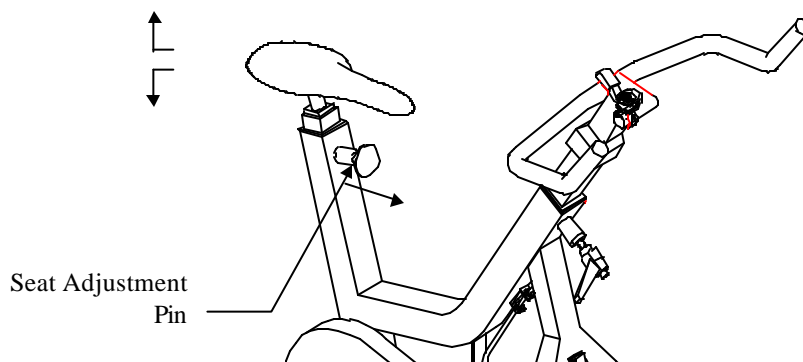

Figure 7

A. Optional Front to Rear Adjustable Seat

1. Keiser Exercise bikes may be ordered with the optional horizontal seat adjustment. This adjustment gives the bike the added personal touch.
2. Grab hold of the seat.
3. Pull the lever that is located directly under the seat, out so that the lever is horizontal with the floor (Figure 8).
4. Slide the seat to the desired position.
5. Push the lever down to secure the seat in place.

Caution!

Always make sure that the seat lever is fully engaged and the seat post is not hanging over the edge of the gib or the seat could come off during use and cause serious injury..

Optional Seat Adjustment

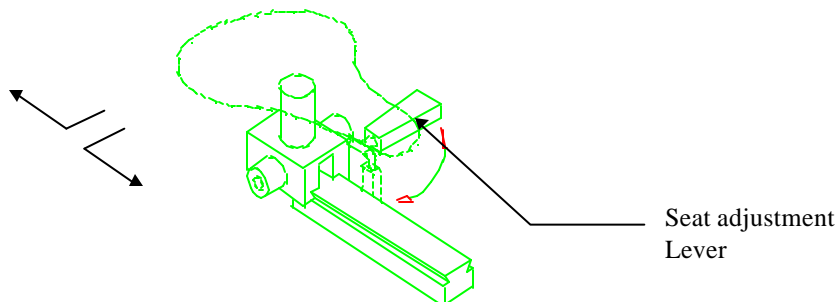

Figure 8

A. Handle Bar Adjustment

1. The handle bars may be adjusted to any height the user may prefer.
2. On the front side of the handle bar mount tube is the adjustment lever.
3. Grabbing hold of handle bars, turn lever counter clockwise. This will loosen the handle bars and allow you to adjust them to your preferred height (Figure 9).
4. Once the handle bars are at the desired height, turn the lever clockwise to tighten them in place.
5. If the lever ends up in a location where it might interfere in the use of the bike during use, the lever may be repositioned *without* changing the tension on the handlebars. Simply depress the button on the shaft of the handle, pull the lever back and reposition the handle.

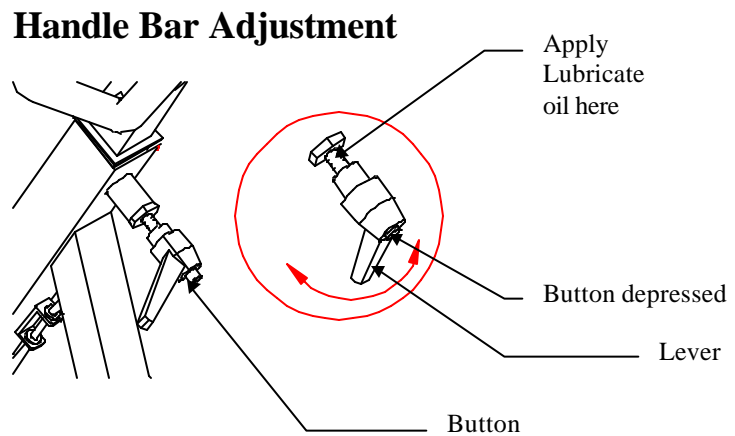

Figure 9

A. Load Adjustment

- A friction belt supplies the desired load. This load may be adjusted by simply turning the Shifter Lever located on the handle bars (Figure 10).

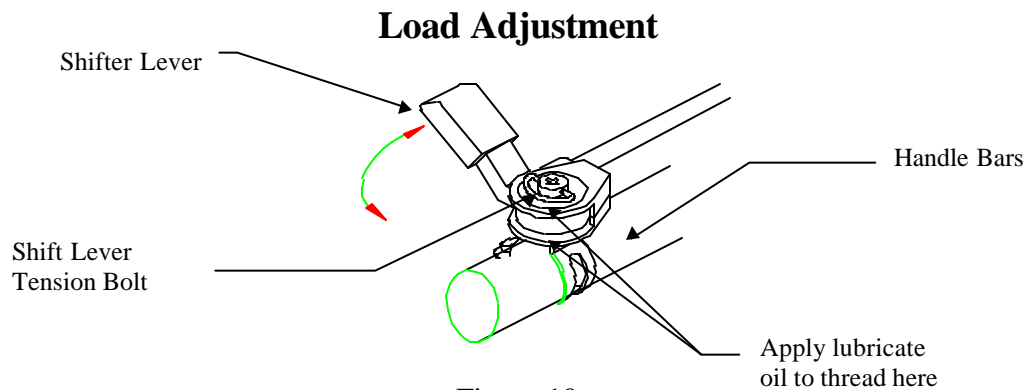

Figure 10

Maintenance Adjustments

A. Removal of Chain Cover

Tools required: #2 Standard Screwdriver

Caution!

Extreme care must be taken not to allow your fingers, clothing, hair, etc. to be drawn into the chain and sprockets. This will cause severe injury.

1. Place the flat end of the screw driver under the head of the five rivets that hold the chain cover on.
2. Gently pry the head up (Figure 11).
3. Once the rivet head is up, pull the entire rivet straight up.
4. Remove all rivets that hold the cover in place.
5. Pull the cover straight out and work it around the pedal assembly.
6. To reinstall the cover, work the cover around the pedal and align the rivet holes.
7. Insert rivets into all holes.
8. Push the rivet heads in.

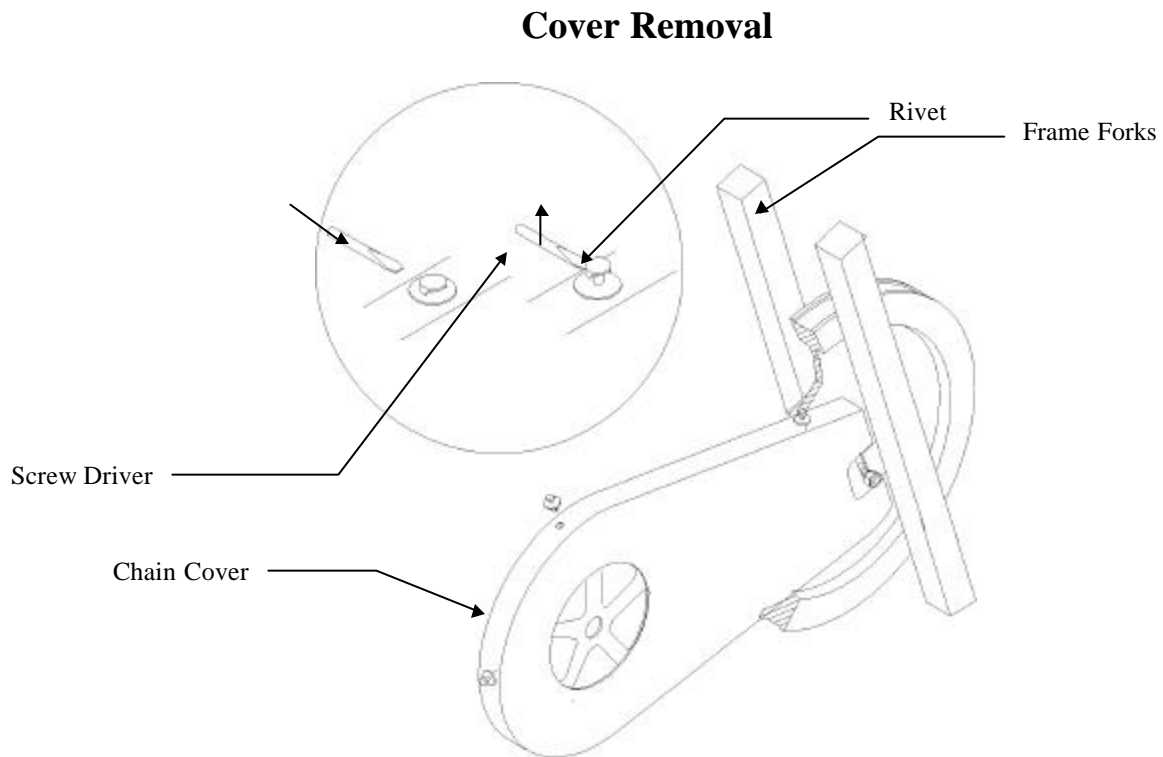

Figure 11

B. Chain Tension & Flywheel Adjustment

Tools required: 9/16” wrench or socket
 Tape measure
 Chain adjustment tool.
 Torque Wrench

Caution!

Extreme care must be taken to not allow your fingers, hair, clothes, etc. to drawn into the chain and sprockets. This will cause severe injury.

1. Maintaining proper chain tension will help to extend the life of the chain and drive components. It is recommended that the chain be checked at the same time it is cleaned. You will need to remove the chain cover, follow the instructions under “*Removal of Chain Cover*”.
2. Set the shift lever at the full load position, counter clockwise (Figure 10), gently move the crank arm back and forth being careful not to rotate the flywheel. The movement of the end of the crank arm (at the pedal) should not be more than **1/8 of an inch**. If the movement of the arm is greater than 1/8 of an inch the chain may be out of adjustment.
3. To more precisely check the tension follow the instructions below:
 - a) Remove the chain cover following instructions under “*Removal of Chain Cover*”.
 - b) Slowly rotate the pedals checking the tension of the chain throughout its rotation. Find the position of the chain where it appears to be the tightest.
 - c) Measure the distance between the chain and the chain cover being careful not to deflect the chain
 - d) Now push the chain upward with the tape measure until the chain will no longer move. The distance that the chain moves should be less than **1/8 of an inch**.
4. If the chain is out of adjustment, loosen the flywheel axle nuts (using 9/16 wrench or socket) allowing flywheel to move to lower position. (Note that each nut may be moved independently eliminating the need for 2 wrenches.) This will allow the chain to reach full tension.

Note!

Make sure the tool is not inserted up side down. Refer to Figure 13.

5. With the flywheel in this position, insert the ‘chain adjustment tool’ as shown in Figure 12. **Tighten axle nut “A” first** (Figure 12). Torque on the flywheel axle nut should be 35 ft-lbs.

Chain Adjustment

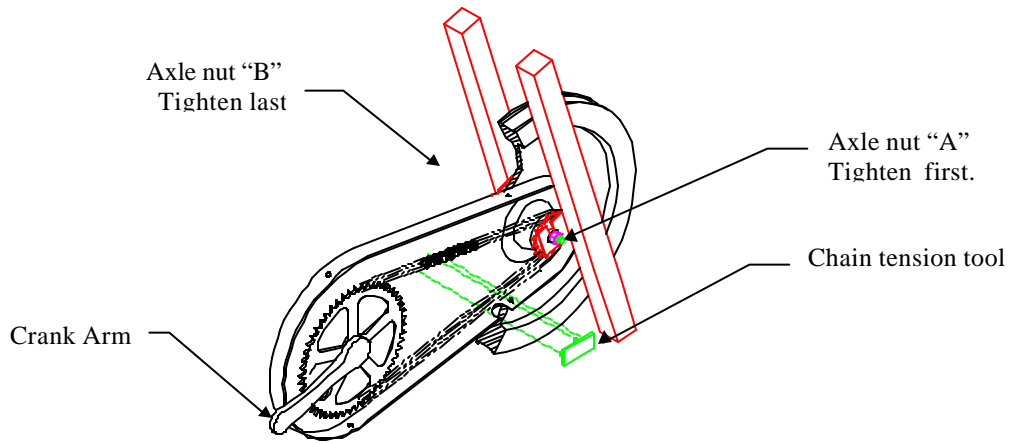

Figure 12

6. Before tightening axle nut "B", the flywheel must be aligned. Alignment requires measuring the distance from one side of the flywheel to the inside edge of the fork tube (Figure 14). Measurement should be taken at the top and bottom of the flywheel. These distances should be about the same (difference should be no greater than 1/8 inch).
7. If the flywheel is out of alignment, be sure **axle nut "B"** is loose. Next, pull the top of the flywheel to either side until the measurements on the top and bottom of the flywheel to the fork fall within the 1/8 inch tolerance (Figure 14).

Chain Tool

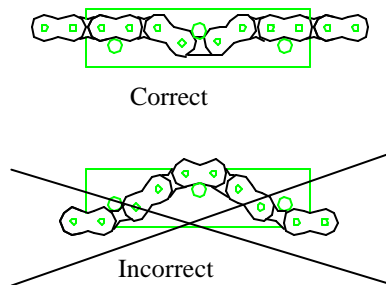
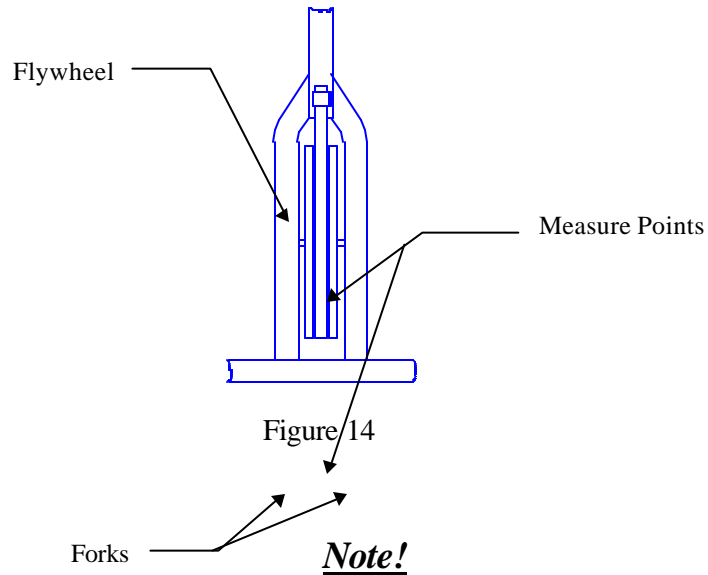

Figure 13

Flywheel Adjustment



Note!

Do not over tighten the nut on the end of the axle. This will result in breaking off the end of the axle or stripping the axle threads. 35 ft-lbs. is equivalent to applying 35 lbs. of weight or force to the end of a 12 inch long wrench. Also make sure to remove chain adjustment tool.

8. Once the flywheel is in position, tighten **axle nut "B"** (torque on the flywheel axle nut should be 35 ft-lb.).
9. **Remove the chain adjustment tool.**

If the chain is properly adjusted and still makes noise, the chain may be worn or one of the chain sprockets may be worn and in need of replacement.

C. Friction Belt Adjustment

Tools Required: Medium Philips screwdriver

1. Place the shift lever in the no load position (turned fully clockwise).
2. Check the tension of the friction belt. The friction belt tension spring should not be extended, no gaps between the coils, (Figure 15A) and there should be little or no tension on the belt.
3. To adjust the friction belt for less tension (Old style Cam Buckle):
 - Lift and release the cam lever on the cam buckle.
 - Pull the friction belt back through the cam buckle relieving some of the tension.
 - Depress and lock the lever on the cam buckle.
 - Recheck the tension on the friction belt and repeat the process if necessary.

Friction Belt Adjustment

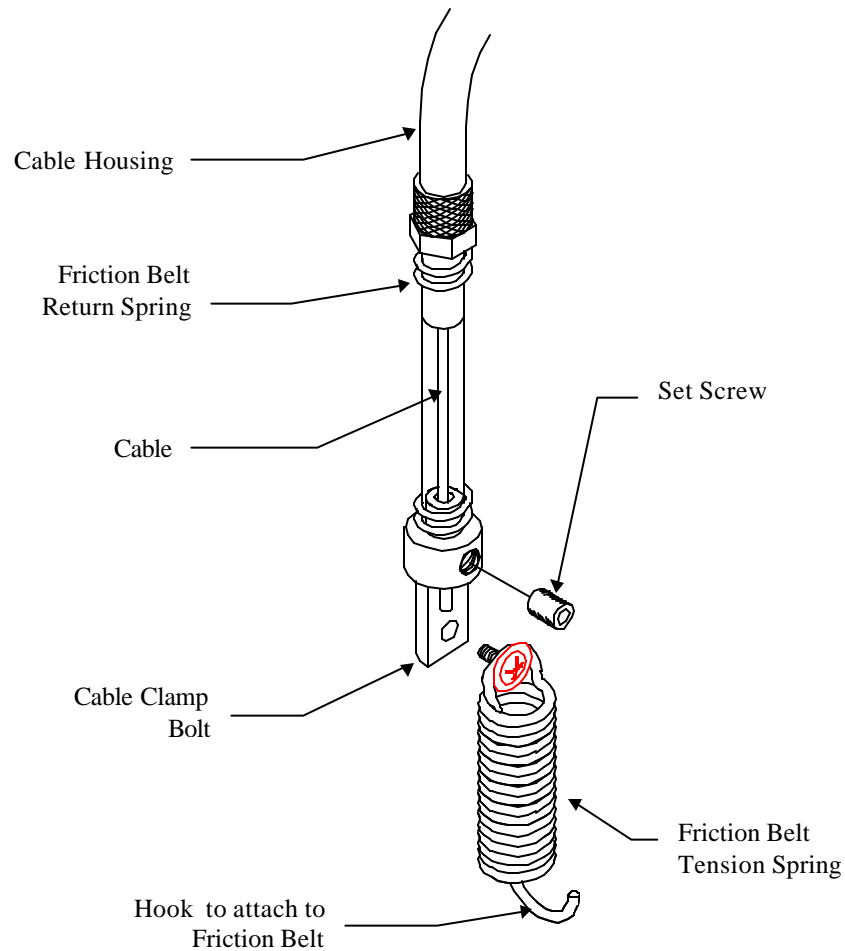

Figure 15

4. To adjust the friction belt for less tension (Clamp Plate):

- Loosen clamp plate where friction belt is attached to frame by loosening the 2 screws.
- Pull the friction belt back through the clamp plate relieving some of the tension.
- Retighten the clamp plate screws.
- Recheck the tension on the friction belt and repeat the process if necessary.

5. To adjust the friction belt for more tension (Old style Cam Buckle or Clamp Plate):

- Lift and release the cam lever on the cam buckle or loosen 2 screws on clamp plate attaching friction belt to frame.
- Pull the friction belt through the cam buckle or clamp plate applying some tension to the friction belt (you should feel the tension spring pull a little).
- Depress and lock the lever on the cam buckle or retighten clamp plate screws.
- Recheck the tension on the strap and repeat the process if necessary.

Note!

The friction belt should not be so loose as to allow the belt to fall out of the groove in the flywheel.

D. Shift Lever Tension

Tools Required: None

1. If the shift lever inadvertently moves during the workout, the lever may be tightened to prevent movement.
2. To tighten the lever, rotate the shift lever tension bolt (see figure 10) clockwise until the desired tension is achieved.

Note!

Three things affect the shift lever tension range.

1.) Friction Belt

2.) Flywheel

3.) Shifter Cable Assembly

If these 3 items are not checked periodically your tension range will decrease, resulting in less load range between your maximum and minimum tension.

E. Seat (Non - adjustable)

Tools Required: 9/16 inch wrench

1. Attach the seat to the seat post such that the post is forward of the clamp bolt. Before tightening the seat clamp bolt, position seat so that it is level and is centered on the parallel section of the seat rails. Be careful to make sure that the clamp is not tightened at a position between serrations as this may allow the seat to slip and damage the serration's on the clamp.
2. Tighten the clamp so the seat will not tilt or rotate inadvertently.

F. Replacement of Friction Belt

Tools Required: None

1. Place the shift lever in the no load position (turned fully clockwise).
2. Release the cam buckle or clamp plate holding the friction belt in place.
3. Unhook the grommet on the other end of the friction belt from the friction belt tension spring.
4. Replace the old friction belt with a new one.
5. Place the end of the friction belt on the hook end of the friction belt tension spring.
6. Wrap the belt around the flywheel (felt against the flywheel) being careful not to twist the belt.
7. Insert the free end of the belt into the cam buckle or clamp plate and follow the instructions in "*Friction Belt Adjustment*".

BOTTOM BRACKET INSTALLATION

*Tools required: Crank arm puller
Torque wrench
Bottom Bracket socket
Loctite 242*

1. Remove the outer chain cover 'A' as described in section "Removal of Chain Cover".
2. Remove crank arm bolt 'B' and discard.
3. Remove crank arm bolt 'C' and discard.
4. Using crank arm puller, remove the right side crank arm 'D'.
5. Using crank arm puller, remove the left side crank arm 'E'.
6. With splined bottom bracket socket, remove the left side bottom bracket cup 'F' and discard. ***This cup is right-hand threaded meaning you turn the tool counterclockwise to remove the cup.***
7. Using splined bottom bracket socket, remove the bottom bracket cartridge 'G' and discard. ***The cartridge 'G' is left-hand threaded meaning you turn the tool clockwise to remove the cartridge.***

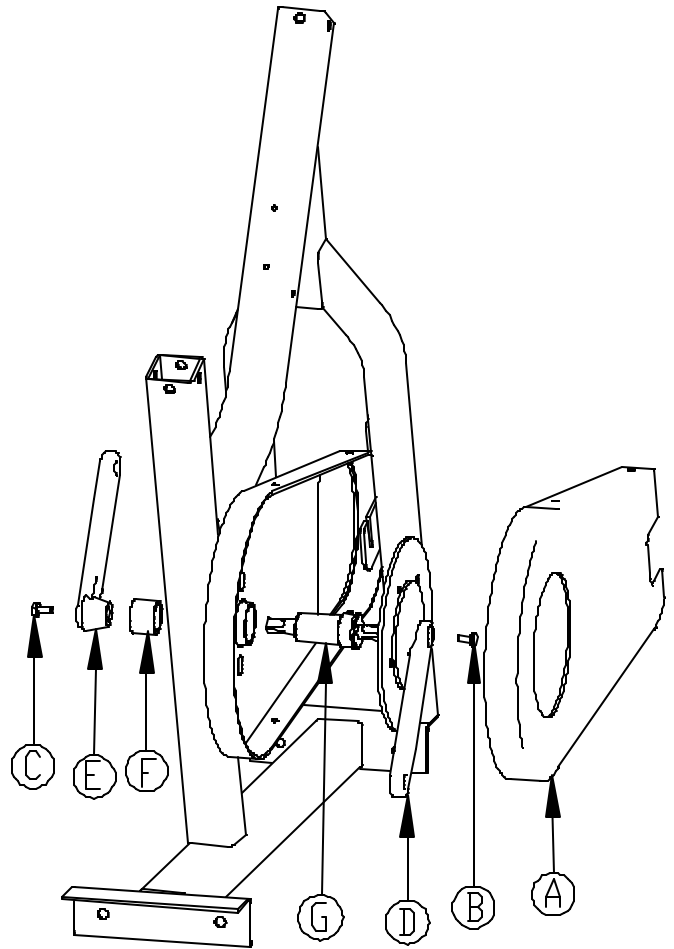

Note!

Remove old Loctite residue from threads on both sides of bike frame (where you removed the bottom bracket cartridge and the bottom bracket cup) with a clean cloth.

8. Apply 3 drops of Loctite 242 to the threads of the new bottom bracket cartridge 'G'. ***Do not allow any Loctite to drop onto the painted frame as it will damage the painted surface.***

Warning!

Failure to install the new bottom bracket cartridge and new bottom bracket cup with Loctite 242 will void the warranty and could lead to serious injury.

9. Reinsert the ***new*** bottom bracket cartridge with Loctite on the threads into the frame. The cartridge is ***left-hand threaded*** so you will need to turn it counterclockwise to screw it into the frame.

Warning!

Failure to torque the new bottom bracket cartridge to 57 ft-lbs. will void the warranty and could lead to serious injury.

10. Using the splined bottom bracket socket on a torque wrench, tighten the cartridge bottom to a torque of 57 ft-lbs.
11. Apply 3 drops of Loctite 242 to the threads of the **new** bottom bracket cup 'F'. ***Do not allow any Loctite to drop onto the painted frame as it will damage the painted surface.***
12. Reinsert the **new** bottom bracket cup with Loctite on it into the left side of the frame. ***The cup is right-hand threaded so you will need to turn it clockwise to screw it into the frame.***

Warning!

Failure to torque the new bottom bracket cup to 57 ft-lbs. will void the warranty and could lead to serious injury.

13. Using the splined bottom bracket socket on a torque wrench, tighten the **new** bottom bracket cup with Loctite on it to a torque of 57 ft-lbs.
14. Place the left side crank arm 'E' onto the spindle of the left side of the bottom bracket.
15. Place the right side crank arm 'D' onto the spindle of the right side of the bottom bracket.

Warning!

Failure to follow the following instructions regarding applying Loctite 242 to the threads of the crank arm bolts for both sides of the crank arm and for tightening both crank arm bolts to a torque of 30 ft-lbs. will void the warranty and could lead to serious injury.

16. Apply 1 drop of Loctite 242 to **new** crank arm bolt 'C'. Screw bolt into left side of frame and torque to 30 ft-lbs. ***Do not allow any Loctite to drop onto the painted frame as it will damage the painted surface.***
17. Apply 1 drop of Loctite 242 to **new** crank arm bolt 'B'. Screw bolt into right side of frame and torque to 30 ft-lbs. ***Do not allow any Loctite to drop onto the painted frame as it will damage the painted surface.***
18. Reinstall the chain and tension it as described in the section "*Chain Tension & Flywheel Adjustment*".

Torque Specifications

- 1. Pedals35 ft-lb.
- 2. Crank Arm Bolts.....30 ft-lb.
- 3. Bottom Bracket
 - Fixed Side (left hand thread / chain side).....57 ft-lb.
 - Adjustable side (right hand thread).....57 ft-lb.
- 4. Flywheel Axle Nuts..... 35 ft-lb.
- 5. Feet attachment bolts..... 15 ft-lb.

Optional Tools offered through Keiser Corporation

Description	Keiser Part Number
1. Bottom Bracket Socket	50-5427
2. Crank Arm Puller	50-5428
3. RemGrit TFL-50 Dry Lubricant	50-5436
4. Torque Wrench U-90 lb.	50-5439
5. Chain Tension Tool	50-0908
6. Loctite 242	10-5550
7. Sanding Sponge	50-5409
8. Tool Kit (containing all tools)	50-0804
9. RemGrit TFL 50 Wet Lubricant	50-5463
10. 15mm Crows Foot	50-5471

TROUBLESHOOTING

Vibration during use:

Flywheel may not be adjusted properly. Follow procedures outlined in “*Chain Tension & Flywheel Adjustment*”.

Chain Falls off:

Chain has too much slack. Follow procedures outlined in “*Chain Tension & Flywheel Adjustment*”.

Excessive Noise from Chain:

Chain is too tight. Follow procedures outlined in “*Chain Tension & Flywheel Adjustment*”. Check chain cover for rubbing or Chain is worn out. Replace chain.

Full Load not enough:

Friction belt is out of adjustment. Follow procedures outlined in “*Friction Belt Adjustment*”. If adjustments are acceptable, check friction belt for worn spots.
If worn, replace belt.

Load is too high:

Friction belt is out of adjustment. Follow procedures outlined in “*Friction Belt Adjustment*”.

Warning!

Failure to follow the assembly or operation instructions as provided by this manual or any other instructions pertaining to the assembly and/or operation of KEISER equipment will result in voiding the warranty and could lead to serious injury.

**FREE WHEEL (5000) / POWER PACER (5100)
MECHANICAL BICYCLE**

ITEM	PART NO.	DESCRIPTION	ITEM	PART NO.	DESCRIPTION
1	505410.80	SEAT-STANDARD	36	501810.80	BELT ANCHOR CLAMP PLATE
3	500831.60	SEAT POST-NON ADJUSTABLE	37	9158.00	HHCS 1/4-20 X 2 1/4 SS
4	500830.60	SEAT POST-ADJUSTABLE	38	9237.00	HEX ELAS LOCK NUT 3/8-16 UNC
5	500832.60	QUICK REL W/ ADJ POST ASSY	39	9347.00	3/8 FLAT WASHER
7	9265.00	PHCSS 1/4-20 X 3/4 SS	40	505416.00	16 TOOTH SPLD COG (PWR PACER)
8	9035.00	SHCS 1/4-20 X 3/4" SS	41	505426.80	NUT 1 3/8-24 (PWR PACER)
10	9226.00	HEX REV LOCK NUT 5/16-18 UNC	42	500902.33	BOTTOM FRAME WITH CASTERS *
11	505425.80	CHAIN	43	9279.00	HWH TFTDC 5/16-18 X 3/4 ZP
12	505424.80	CRANK ARM-170MM S	44	505058.80	2" CASTER
13	505403.80	PEDAL SET COMBO	45	505442.80	FRICITION BELT
14	505444.00	PEDAL SET-STRAP/ TOE CAGE	46	505480.80	RIVET-PLASTIC FOR CHAIN GUARD
15	505406.80	PEDAL SET-LOOK STYLE	47	505001.80	FLYWHEEL
16	505464.80	REGULAR PEDALS	48	502200.80	FLYWHEEL AXLE
17	115404.00	HOLE PLUG 1.0"	49	225400.00	BEARING 6203 2 SEALS
18	115054.00	PLASTIC-CAP 2" SQUARE	50	505063.80	PLASTIC PIN 1/4
19	105423.00	BUMPER-MOLDED GLIDE	51	500901.33	HANDLE BAR WELDMENT
20	504202.33	BOTTOM FRAME *	52	500810.00	SHIFT / CABLE ASSY.
21	505060.80	CHAIN COVER-MALE / FEMALE	53	505407.80	RUBBER GROMMET
22	265404.00	PLASTIC RIVET	54	105443.00	DECAL / SERIAL # LABEL
23	9194.00	HHCS 5/16-18 X 3/4 SS	56	115371.00	KEISER DECAL - SMALL
24	9369.00	AIRCRAFT WASHER 5/16 SS	58	505301.80	DECAL - POWER PACER
25	505418.80	BEARING/AXLE ASSY-BOTTOM BRKT	59	505300.80	DECAL - FREE WHEEL
26	500910.33	MAIN FRAME *	60	505408.80	FRICITION BELT TENSION SPRING
27	172180.80	PLUNGER	62	505417.80	SPROCKET-16T (FREEWHEEL)
28	175500.00	SPRING-PLUNGER	63	9219.00	HEX REV LOCK NUT 1/4-20 SS
29	505302.80	DECAL-WARNING (BIKE)	64	9261.00	PHIL PH M/S 10-32 X 1/4 SS
30	505068.80	BUSHING 4-PIECE	66	505495.80	NYLON WASHER
31	502160.80	SLUG-HANDLE BAR ADJUSTMENT	67	505057.80	HANDLE BAR WIPER SEAL
32	175420.00	BLACK KNOB	68	9007.00	COTTER PIN
33	505470.80	WATER BOTTLE CAGE	69	215502.00	SPRING RING
34	112244.00	THREADED NUT	70	9381.00	CRANK ARM BOLT
35	505419.80	HANDLE STUD ASSY.	71	9178.00	HHCS 5/16"-18 X 2 ZP

* SPECIFY COLOR

KEISER[®]

KEISER SERVICE DEPT
1 (800) 888-7009

KEISER CORPORATION
2470 S. Cherry Avenue
Fresno, CA 93706-5004
(559) 256-8000

50-5500 Rev. H